

E. F. Howard,
Manf. of Ordnance.

No 40,039.

Patented, Sep 22, 1863.

Fig 3.

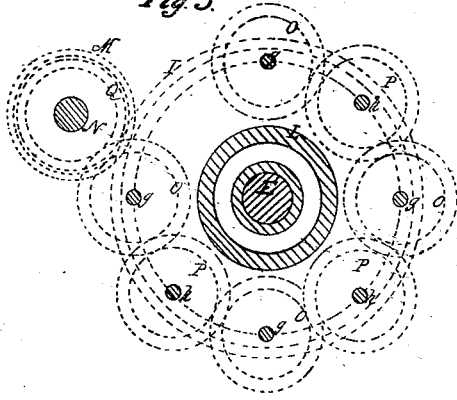

Fig 2.

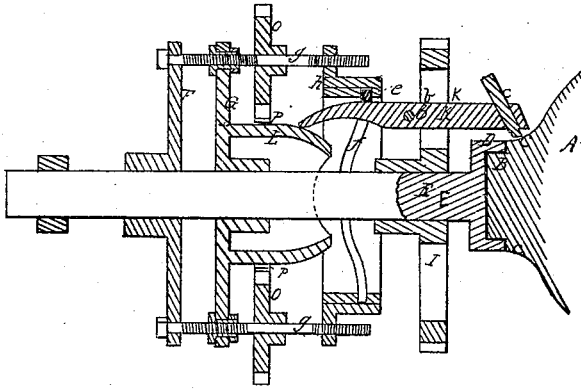
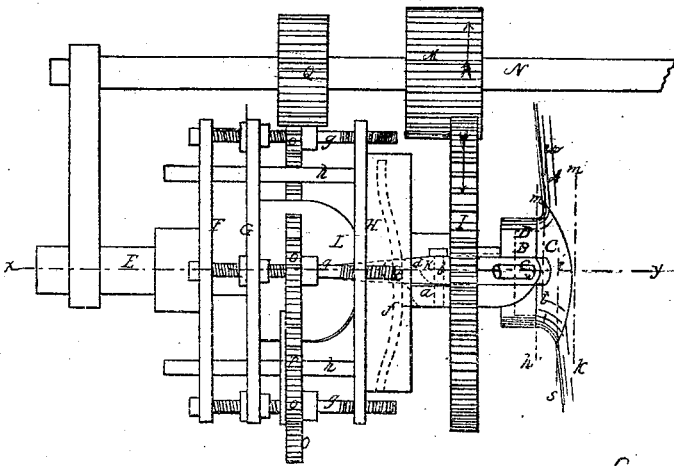

Fig 1.



Witnesses:

W. B. Crosby
W. F. Gould

Inventor:

Edward F. Howard

UNITED STATES PATENT OFFICE.

E. F. HOWARD, OF BOSTON, MASSACHUSETTS.

IMPROVEMENT IN MACHINERY FOR FINISHING RIM-BASES OF ORDNANCE.

Specification forming part of Letters Patent No. 40,039, dated September 22, 1863.

To all whom it may concern:

Be it known that I, E. F. HOWARD, of Boston, county of Suffolk and State of Massachusetts, have invented a Machine for Finishing the Rim-Bases of Ordnance; and I do hereby declare that the following, taken in connection with the drawings which accompany and form part of this specification, is a description of my invention sufficient to enable those skilled in the art to practice it.

In finishing the surfaces of metal ordnance the cylindrical parts of the body of the cannon are turned or cut down in a lathe, excepting that portion of the said surfaces lying between the trunnions of the gun, which parts are planed down in a planer. The trunnions, being cylindrical, are turned down in the same manner, and these processes finish the outer surfaces of the gun, except the rim-bases or those portions connecting the trunnions to the barrel or body of the piece. Where these are made cylindrical they can be cut down by a lathe and planing machine, but where they curve from the shouldered ends thereof adjacent to the trunnion to and flush with the surface of the gun some other means are necessary to finish or cut down said surfaces. In the manufacture of pieces having such rim-bases they are generally chipped down by hand labor, the operation being very laborious, lengthy, and expensive. I have sought, therefore, to adapt a mechanism to perform this work, and my present invention relates to and consists in a method of automatically operating a cutting-tool to cut the curved surfaces of these rim-bases.

The mechanism embodying my invention is shown in the accompanying drawings, Figure 1 representing a plan of the same, and Fig. 2 a central section taken on the line *xy* of Fig. 1. Fig. 3 shows the arrangement of gears for operating the mechanism.

A denotes a portion of the barrel or body of the cannon, from the side of which the trunnion B extends, the trunnion and body being joined by the rim-bases C. The trunnion extends into a chuck or collar, D, the outer surface of which is made cylindrical and flush with the circumference of the outer edge of the rim-base, or to the circumference which said rim-base is to have when finished. This chuck is fixed upon or forms the end of a stationary shaft, E, and when chucked to the

shaft the axial line of the trunnions and shaft E is the same, said axial line being perpendicular to the axis of the gun-barrel. This shaft carries or has fixed upon it a stationary plate, F, and a sliding pattern-plate, G, and parallel to these plates a cam-plate or ring, H, is placed, as seen in Figs. 1 and 2. Between this ring H and the chuck D the shaft E bears a loose or sliding gear, I, from the rear face of which an ear or projection, *a*, extends. A rocking lever or tool-holder, *k*, turns on a pin, *b*, fixed to the projection *a*. The front end of this holder carries the tool or cutter *c*, while its rear end rests upon and is operated radially or to and away from the axial line of the trunnions by the surface of a cam, former, or pattern L, which extends out from the front face of the sliding plate G, as seen in Figs. 1 and 2. From the projection *a* an arm, *d*, extends, such arm carrying a cam-pin, *e*, which extends into and is worked by a grooved cam, *f*, extending around the inner surface of the cam-ring H. This cam gives a reciprocal longitudinal movement to the cutter toward and away from the axial line of the barrel of the gun.

Rotary motion is given to the gear I, and thence to the cutter or tool *c*, by a gear, M, on a shaft, N, or in any other convenient manner. Rotation of the gear I carries the cutter around the rim-base in a circular direction. As the cutter rotates, it is held in proper position to cut the required curvature on the rim-base parallel to the axis of the trunnion by the bearing of the rear end of the tool-holder on the pattern-surface L, and parallel to the axis of the gun-barrel by the grooved cam *f*. The reciprocal movement of the tool produced by the cam *f* at each revolution is not over the whole width of surface of the rim-base from the line *h' n* to the line *km'*, but only over a portion of said width of surface, the tool having a progressive movement given to it toward the axis of the gun. This movement is produced as follows: From the fixed plate F on the shaft E a series of screw-shafts, *g*, extend, connecting said plate with the cam-plate H, the screws working through female threads in said cam-plate. Gears are fixed upon and rotate said screw-shafts, and these gears are connected together by intermediate gears, P, running loosely on rods or shafts *h*, fixed to the plate H, and sliding through the plate F.

A gear, Q, on the shaft N meshes into and actuates one of the gears *o*, and thereby the train of gears *o* and P and screw-shafts *g*, rotation of the gear Q in the direction denoted by the arrow in Fig. 1 causing the movement of the cam-plate H and cutter *c* toward and perpendicular to the axis of the cannon. As the cutter moves forward onto the enlarged part or portion of the rim-base, or toward the part thereof which joins the body of the gun, it is guided by the contact of the opposite end of the tool-holder, which impinges against the diminishing contour of the pattern surface L, and the movement of the tool or cutter by the cam groove *f* is so regulated that when the cam-plate or ring H is completing its outward movement the cutter shall traverse horizontally from the plane *s i* to the plane *k m'*, and from the plane *k m'* to the plane *u t*, the contour of the pattern L regulating as the cutter feeds up its distance from the center or axial line of the trunnion. The plate G, which bears the pattern L, is provided with nuts or screw-threads, through which the screw-shafts *g* work, said screw-shaft being provided adjacent to said nuts with left-handed screw-threads, so that when the rotation of the gears feeds the cam-plate H forward or toward the rim-base the pattern-plate G and its pattern L shall receive a corresponding retrograde movement. By this means while the tool is fed forward an inch onto the rim-base, or toward the axis of the gun, the pattern falls back an inch, thereby separating the pattern and cam-plate two inches. The purpose of this is to give the pattern lengthwise a longer or more gradual curve than the curve to be given to the rim-

base, so that the guiding end of the tool-holder, in its reciprocal movement over the cam-surface, shall have a less abrupt curvature to move over than if the pattern remained stationary and its curvature was the exact reverse of the curvature of the rim-base. This feature, however, is not essential to the working of the mechanism, as the pattern may be so curved as to operate the tool without any such rear movement.

Thus it will be seen that in carrying out my invention I give to the cutting-tool automatic movements, as follows: A rotary movement around the rim-base, a radial movement parallel to the face of the trunnion, a reciprocating longitudinal movement parallel to the axis of the trunnions, and a progressive movement toward the axis of the gun.

I do not confine my invention to the precise arrangement of the gears, and other parts of the mechanism, as shown, as the same may be altered or modified as circumstances require.

I claim—

1. Finishing or cutting the rim-bases of ordnance by the employment of a cutting-tool guided automatically by a pattern, cam, rotating and feeding mechanism, substantially as described.

2. Giving to the pattern L the reverse movement in the manner and for the purpose as set forth.

In witness whereof I have set my hand this 17th day of August, A. D. 1863.

EDWARD F. HOWARD.

In presence of—

J. B. CROSBY,
F. GOULD.